

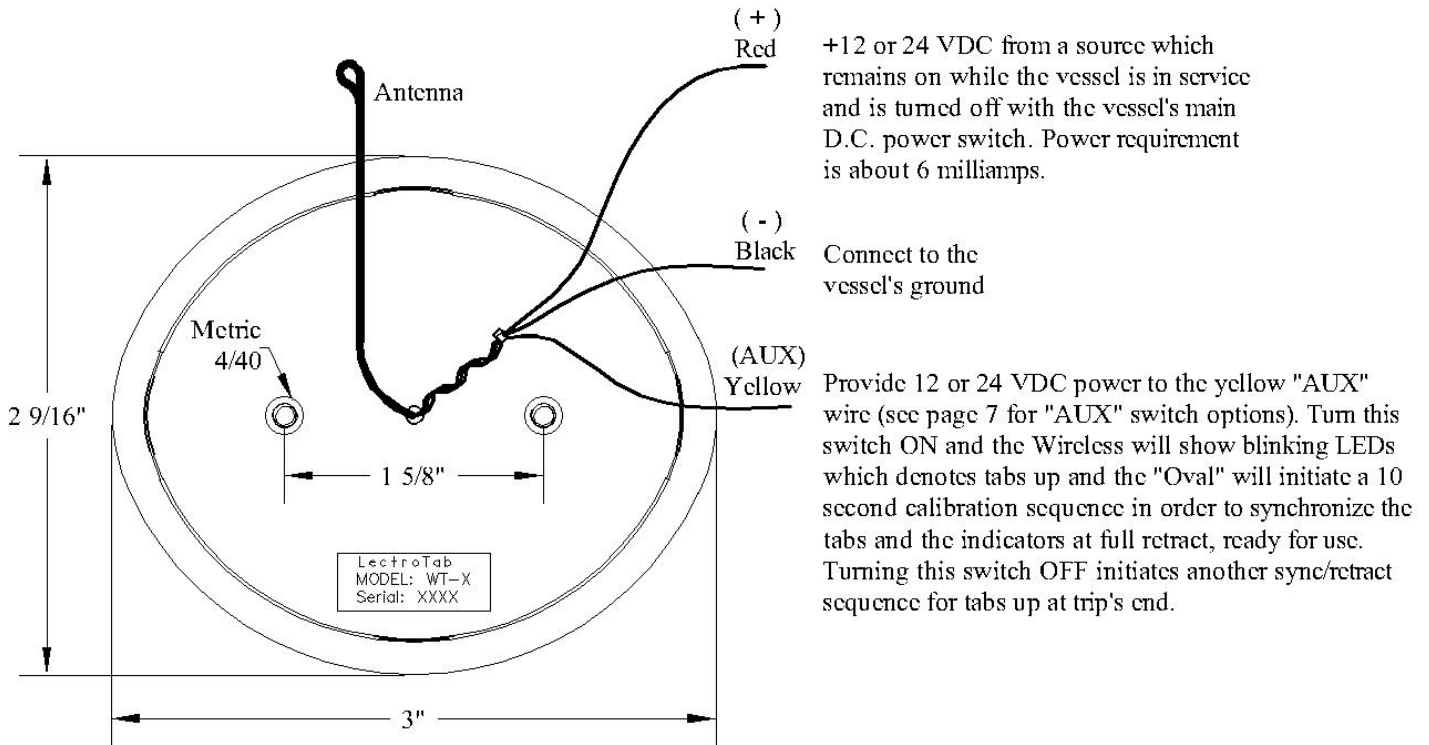

## THE SERIES WTR “WIRELESS” TAB CONTROL INSTALLATION GUIDE

Models: WTR-111, Single Station, 12VDC Only  
WTR-121, Dual Station, 12VDC Only  
WTR-211, Single Station, 24VDC Only  
WTR-221, Dual Station, 24VDC Only



### CONTROL MODULE, MODEL WT-1 (12 or 24VDC)

1. The wireless system control module, model WT-1 (*shown above*), will fit over a 2 1/16" diameter hole and can be secured with the included bracket. Or, all the wires will fit through a 5/8" diameter hole with the control held to the panel either with adhesive or with the two included bolts and a bracket, 1 5/8" apart as noted. The bolts are metric, 4/40 x 60, with take up nuts and lock washers.
2. Position the antenna so it extends straight back, away from the center of the control. Then about 1 inch from the antenna's exit point, bend it upward, 90° in about a 1/4" radius, so that the rest of the antenna is parallel with the back of the control. Let the antenna HANG LOOSE in this position. DO NOT change its length. Position the three wires away from the antenna.

### **-IMPORTANT-**

*Connect the yellow wire to an auxiliary switch, or a dedicated "Trim Tab" switch. See page 7 for AUX wire options. If the yellow and red wires are connected together, the tab retract feature cannot work, and the control can only be turned off by turning off the red wire.*

## WT Wireless Keypad (REAR VIEW W/ TEXT UP)

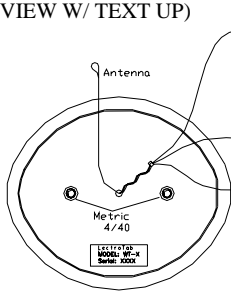

(+) +12 or 24 VDC from a source which remains on while the vessel is in service and is turned off with the vessel's main D.C. power switch. Power requirement is about 75 milliamps/keypad. Use a 250ma fuse.

(-) Connect to the vessel's battery (-)

(AUX) Must connect 12 or 24 VDC power to the yellow "AUX" wire (see page 8 in the manual for "AUX" switch options). Turn this switch ON, and a 10 second calibration sequence initiates in order to synchronize the tabs and the indicators at full retract position. The Wireless will show blinking LEDs which denotes tabs up. Turning this switch OFF initiates another sync/retract sequence for tabs up at trip's end. Use a 250ma fuse.

### Note 1:

#### Wireless Control Models:

- WTR-111 = Single Station 12vdc with 1 Keypad and 1 Power Module
- WTR-121 = Dual Station 12vdc with 2 Keypads and 1 Power Module
- WTR-211 = Single Station 24vdc with 1 Keypad and 1 Power Module
- WTR-221 = Dual Station 24vdc with 2 Keypads and 1 Power Module

Lectrotab  
Single Station Wireless Control  
Installation Wiring Diagram  
6-17-09

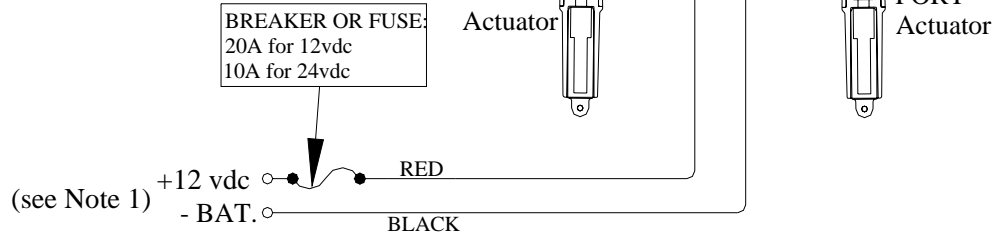

Fully extend antenna vertically and secure with a screw through the loop. Do Not Shorten Antenna Length.

Test Notes:  
Short C to D to deploy both tabs.  
Short C to R to retract both tabs.  
  
If key presses on WT do not create a response from WR, frequency matching may be necessary. Do this by connecting a jumper wire between L and +12vdc then press 'ALL UP'. Remove jumper.

## WR Wireless Power Module

### POWER MODULE, MODEL WR-1 (12 VDC Only), WR-2 (24 VDC Only)

1. The wireless system power module, Model WR-1 or -2, is designed to be installed inside the boat, on the transom, preferably amidships, and is the junction for the actuators and the system input power, 12 VDC, fused at 20 AMPS and 24 VDC, fused at 10 AMPS.
2. Connect the actuators and input power as shown. The input voltage to the WR must match the voltage rating of the actuators (WR-1 = 12VDC Only, WR-2 = 24VDC Only).
3. Secure the antenna vertically, using a small screw through the loop at the end. Point it upward and fully extended. Keep the antenna separated as much as is practical from electric motors as well as other electrical devices. DO NOT change its length.

### NOTE

*In metal boats or in boats with high machinery density in the transom area, if the wireless communication is erratic, random repositioning of the antenna will be helpful.*



## **-DUAL STATION WIRELESS- (WTR-121, 12VDC, WTR-221, 24VDC)**

*The “Dual Station Wireless” control operate independently of each other. We recommend performing an “All Tabs Up” recalibration when moving from one station to the other. Refer to installation diagrams on last page.*

### **-MODULE FREQUENCY MATCH PROCEDURE-**

*The complete Lectrotab wireless control system, series WTR consists of the control module (transmitter, module WT-1) and the power module (receiver, model WR-1 or -2). When shipped, the two modules are frequency matched and will only communicate with each other. Frequently matched modules have identical serial numbers. During the installation, check to make sure the serial numbers on each module match. If they do not match, such as if one is being replaced, the “frequency match” procedure must be run. Proceed as follows:*

1. Establish power to the WR-1 (12 VDC) or WR-2 (24 VDC) power module.
2. Turn on the switch which powers up the yellow wire on the WT-1 control module and confirm that the two LED’s at the top are blinking.
3. With a temporary jumper, at the power module, connect “+” to “L”.
4. Firmly press and release the “ALL UP” button on the control module.
5. Remove the jumper at the power module. The two components are now frequency matched.

### **CHECKOUT**

1. Establish power to the control module and to the power module.
2. Turn on the switch which powers up the yellow wire on the WT-1 control module and confirm that the two LED’s at the top are blinking.
3. Press and release the “TABS DOWN” button and observe that the tab indicator LED’s light progressively downward at one second intervals, and that the tabs deploy to the fully down position and stop.
4. Press and release the “TABS UP” button and confirm that the indicator LED’s extinguish progressively upward and that the tabs retract to the fully up position and stop.



5. Press and hold “STBD BOW DOWN” and observe that the left hand indicator shows tab movement and that the PORT tab deploys down. Press “STBD BOW UP” and confirm that the PORT tab retracts.
  
6. Press and hold “PORT BOW DOWN” and observe that the right hand indicator shows tab movement and that the STARBOARD tab deploys down. Press “PORT BOW UP” and confirm that the STARBOARD tab retracts.

**- IMPORTANT -**

*If any checkout item does not produce the stated results, double check all of the wiring. Also, based on numerous tests, we have set the wireless system transmitter power at a level sufficient to transit numerous bulkheads, machinery spaces and other obstructions for reliable operation in vessels, to about 100', however, this power level may result in unreliable operation at module separation distances of less than 5 feet. Questions, call 888-LECTROTAB.*

**PROGRAMMING**

The WTR series wireless system can be field programmed to effect three changes in the display as follows:

**1. Change the Indicator LED Timing**

*The tab position indicator LED's are shipped from the factory programmed to move full scale in 8 seconds, to accommodate 8 second stroke time tab actuators. However, if Lectrotab 4 or 6 second actuators are being used, the display timing can be reset for 4 to 12 seconds in one second increments. Enter this programming mode as follows:*

- 1) Trim Tab main power ON. Aux. switch OFF\*
- 2) Push & hold the “PORT BOW DOWN” switch and while continuing to hold, turn the AUX switch ON
- 3) Release the “PORT BOW DOWN” switch to enter the programming mode\*\*

*You will see 8 LED's blinking, on the right, which is the factory setting and indicates that the timing is in the 8 second mode. To change the timing, use the “STBD” switch. Use “UP” to increase the number of LED's lit and “DOWN” to decrease the number of LED's lit. (More than 8 will spill over to the top of the left LED's.) The number of LED's lit equals the timing in seconds. To exit, press and release the “PORT BOW UP” switch. Turn the AUX switch “OFF”. Programming will be exited and the control will be ready for use with the changes made.*

*\*The AUX switch is the switch to which the yellow wire is connected and which “wakes” the control up. This may be any of the options on page 7. See your boat owner's manual or ask the installer for the option used.*

*\*\*Once programming is entered, if no entries are made within 90 seconds, the programming mode is exited and no changes are made.*



## **2. Swap Indicator LED'S**

*The tab position indicator LED's are shipped from the factory programmed to match the tabs, i.e. Left LED's show Left tab position and right LED's show Right tab position. This can be field programmed to be reversed, if preferred. Enter this programming mode as follows:*

- 1.) Trim Tab main power ON. Aux. Switch OFF\*
- 2.) Push & hold the "ALL UP" Button and while continuing to hold, turn the AUX switch ON
- 3.) Release the "ALL UP" Button to enter the programming mode.\*\*

*You will see 8 LED's lit on one side. If on the Right side, the indicators match the tabs, Left & Right, which is the factory setting. If on the left side, the indicators match the switches Left and Right. To swap the LED's, press and release the "ALL UP" button. Pressing and releasing again will swap them back, etc. When they are where you want them, press and release the "Port BOW UP" switch. Turn the aux switch "OFF". Programming will be exited and the control will be ready for use with the changes made.*

*\*The AUX switch is the switch to which the yellow wire is connected and which "wakes" the control up. This may be any of the options on page 7. See your boat owner's manual or ask the installer for the option used.*

*\*\*Once programming is entered, if no entries are made within 90 seconds, the programming mode is exited and no changes are made.*

## **3. Turn off the Indicator LED'S**

*The tab position indicator LED's are shipped from the factory programmed to be on, but, if preferred, the LED's can be field programmed to be off at all times. Enter this programming mode as follows:*

- 1.) Trim Tab main power ON. Aux. Switch OFF\*
- 2.) Push & hold the "ALL DOWN" button and while continuing to hold, turn the AUX switch ON
- 3.) Release the "ALL DOWN" Button to enter the programming mode\*\*

*You will see all LED's blinking, left and right, which is the factory setting and indicates that the LED's are in the ON mode. To enter the "LED's OFF" mode, press and release the "ALL UP" button which will display the two lower LED's blinking on both sides. This is the LED's "OFF" mode. Pressing and releasing again will swap them back, etc. When they are in the mode you want, press and release the "Port BOW UP" switch. Turn the AUX switch "OFF". Programming is now exited and the control is ready for use with the changes made.*

*\*The AUX switch is the switch to which the yellow wire is connected and which "wakes" the control up. This may be any of the options on page 7. See your boat owner's manual or ask the installer for the option used.*

*\*\*Once programming is entered, if no entries are made within 90 seconds, the programming mode is exited and no changes will be made.*



## Aux Switch Options

### **1.) Using a dedicated “Trim Tab Switch”:**

Connect terminal 3 to an existing or newly installed switch which is convenient to the helmsman to turn the “Oval” on for use, and off at trip’s end for full tab retraction and tab position indicator synchronization at tabs up.

### **2.) Using a conventional multifunction key or rotary switch for “OFF-AUX-IGN-START” with gasoline engine powered boats:**

Connect Terminal 3 to the AUX position of this type switch. DO NOT use the ignition (IGN) position. Whenever the AUX position is turned on or off the “Oval” will respond accordingly. DO NOT use this type switch if it does not have an “AUX” position.

### **3.) Using a conventional multifunction key or rotary switch for “OFF-GAUGES PREHEAT” with diesel engine powered boats:**

Connect terminal 3 to the gauges position of this type switch. Whenever the gauges position is turned on or off, the “Oval” will respond accordingly. DO NOT use the (GAUGES) position if turning off the gauges also stops the engine.

### **4.) Using the “Electronics Master Switch”:**

On many boats, at the helm area, there will be a master switch for the navigation and other electronic equipment which provides a convenient way to turn all of this equipment on and off at the beginning and end of a trip. Connect Terminal 3 to this switch which, when turned off, will initiate the 10 second calibration sequence to synchronize the tabs and indicators, at full retract.

### **5.) Using a "Gearshift Neutral Switch”:**

As noted on page 3, dennergizing the “Oval’s” terminal 3 will initiate a 10 second calibration sequence in order to synchronize the tabs and the indicators at full retract, ready for use. If Terminal 3 remains dennergized, the “Oval” will remain shut down. Alternatively, if Terminal 3 is dennergized and immediately reenergized, the “Oval” will initiate a calibration / retract sequence but will remain on. This feature will accommodate connecting Terminal 3 to a gearshift switch which is \*OPEN CIRCUIT in neutral. In this case, after the engine is started and put in gear, Terminal 3 would be energized, readying the “Oval” for use. Then, at the end of the trip, or when backing down, when the gearshift is returned to neutral, or even passed through neutral to reverse, the “Oval” would initiate a calibration / retract sequence and the tabs will remain retracted, regardless of subsequent gearshift positions until, on the next trip out, the helmsman operates the control for tabs down. This scheme will provide tab retraction upon reaching the docking area instead of remaining down during the docking process waiting to be retracted when the engine is shutdown.

*Of all the ways to have the tabs retract at trips end, we like the gearshift neutral approach the best.*

*\* If the neutral switch is not off at neutral, you can use a Lectrotab model # NR-12 or NR-24 relay assembly to convert a hot neutral switch to an open circuit output for use with the oval. The installation and the wiring is quite simple.*

### WT-1 Wireless Keypad 2nd Station (REAR VIEW W/ TEXT UP)

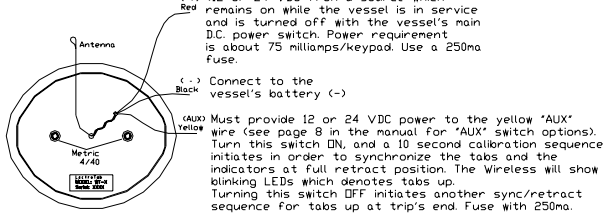

### WT-1 Wireless Keypad 1st Station (REAR VIEW W/ TEXT UP)

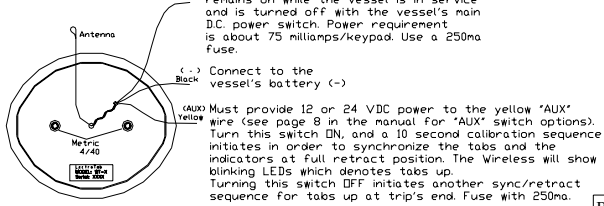

#### Operational Note:

When moving from one station to a new station, it is recommended to press the "ALL UP" button at the new station. The reason for this is both WT Wireless Keypads communicate with the WR power module individually and not between each other. This will allow the new station keypad to initiate an "ALL TABS UP" and calibrate the LED indicators with the power module tab position.

#### Note 1:

##### Wireless Control Models:

- WTR-111 = Single Station 12vdc with 1 Keypad and 1 Power Module
- WTR-121 = Dual Station 12vdc with 2 Keypads and 1 Power Module
- WTR-211 = Single Station 24vdc with 1 Keypad and 1 Power Module
- WTR-221 = Dual Station 24vdc with 2 Keypads and 1 Power Module

Fully extend antenna vertically and secure with a screw through the loop. Do Not Shorten Antenna Length.

Test Notes:  
Short C to D to deploy both tabs.  
Short C to R to retract both tabs.

If key presses on WT do not create a response from WR, frequency matching may be necessary. Do this by connecting a jumper wire between L and +12vdc then press "ALL UP". Remove jumper.

### WR Wireless Power Module

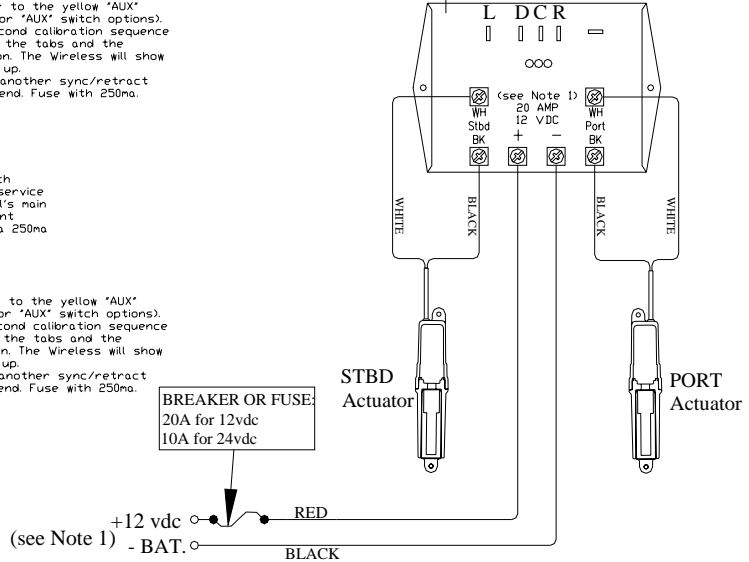

Lectrotab  
Dual Station Wireless Control  
Installation Wiring Diagram  
06-25-09

## The "Wireless " Control 4-Actuator Installation Diagram

### WT-1 Wireless Keypad

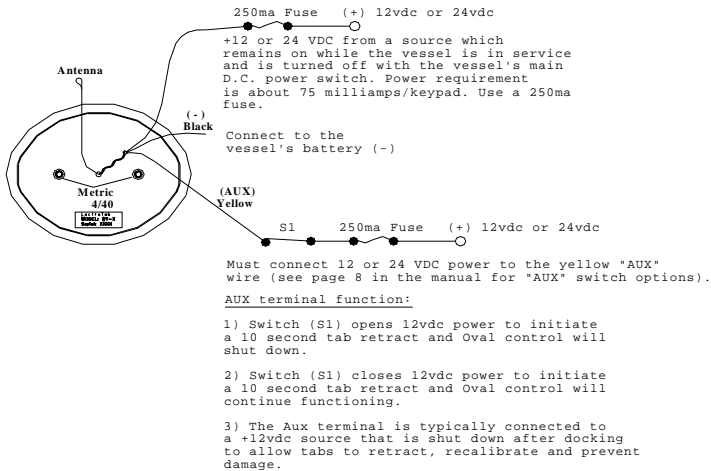

#### Note 1:

##### Wireless Control Models:

- WTR-111 = Single Station 12vdc with 1 Keypad and 1 Power Module
- WTR-121 = Dual Station 12vdc with 2 Keypads and 1 Power Module
- WTR-211 = Single Station 24vdc with 1 Keypad and 1 Power Module
- WTR-221 = Dual Station 24vdc with 2 Keypads and 1 Power Module

Fully extend antenna vertically and secure with a screw through the loop. Do Not Shorten Antenna Length.

Test Notes:  
Short C to D to deploy both tabs.  
Short C to R to retract both tabs.

If key presses on WT do not create a response from WR, frequency matching may be necessary. Do this by connecting a jumper wire between L and +12vdc then press "ALL UP". Remove jumper.

**Wireless Power Module**  
WR-1 (12vdc), WR-2 (24vdc)

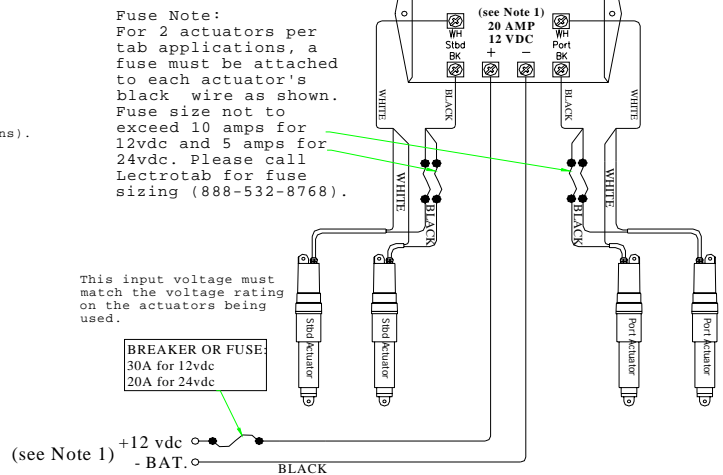

Fuse Note:  
For 2 actuators per tab applications, a fuse must be attached to each actuator's black wire as shown. Fuse size not to exceed 10 amps for 12vdc and 5 amps for 24vdc. Please call Lectrotab for fuse sizing (888-532-8768).

This input voltage must match the voltage rating on the actuators being used.

Lectrotab  
Wireless Control w/ 4 Actuators  
Installation Wiring Diagram  
06-25-09